

J. MASON.

MACHINE FOR CUTTING ROSETTES IN CORNER CASING BLOCKS FOR DOOR FRAMES, BOOK CASES, OR OTHER ARTICLES.

No. 466,963.

Patented Jan. 12, 1892.

Fig 1

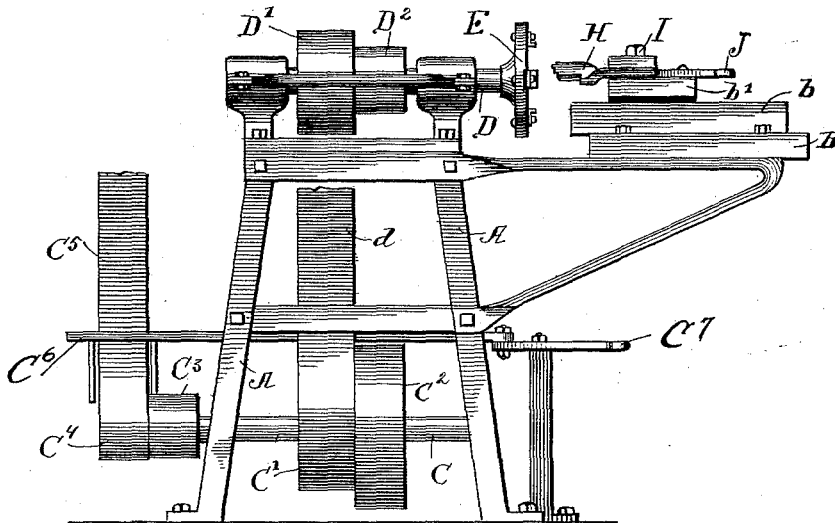
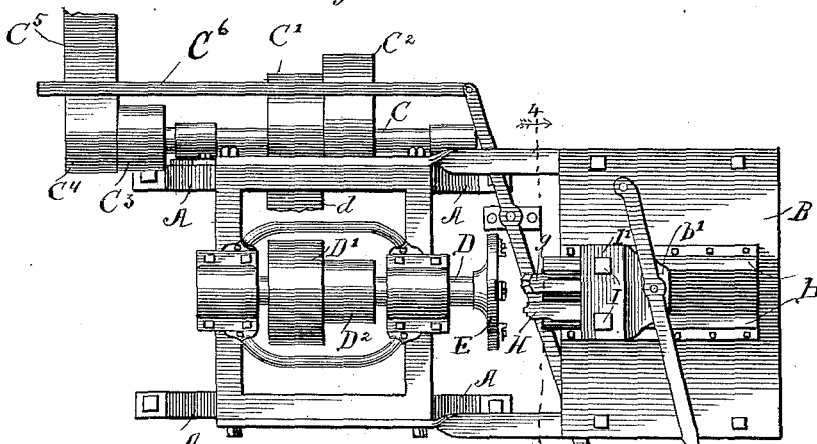

Fig 2



Witnesses
 Lute S. Altor
 Flora S. Brown.

Inventor
 James Mason
 By Charles J. Brown
 Atty.

J. MASON.

MACHINE FOR CUTTING ROSETTES IN CORNER CASING BLOCKS FOR DOOR FRAMES, BOOK CASES, OR OTHER ARTICLES.

No. 466,963.

Patented Jan. 12, 1892.

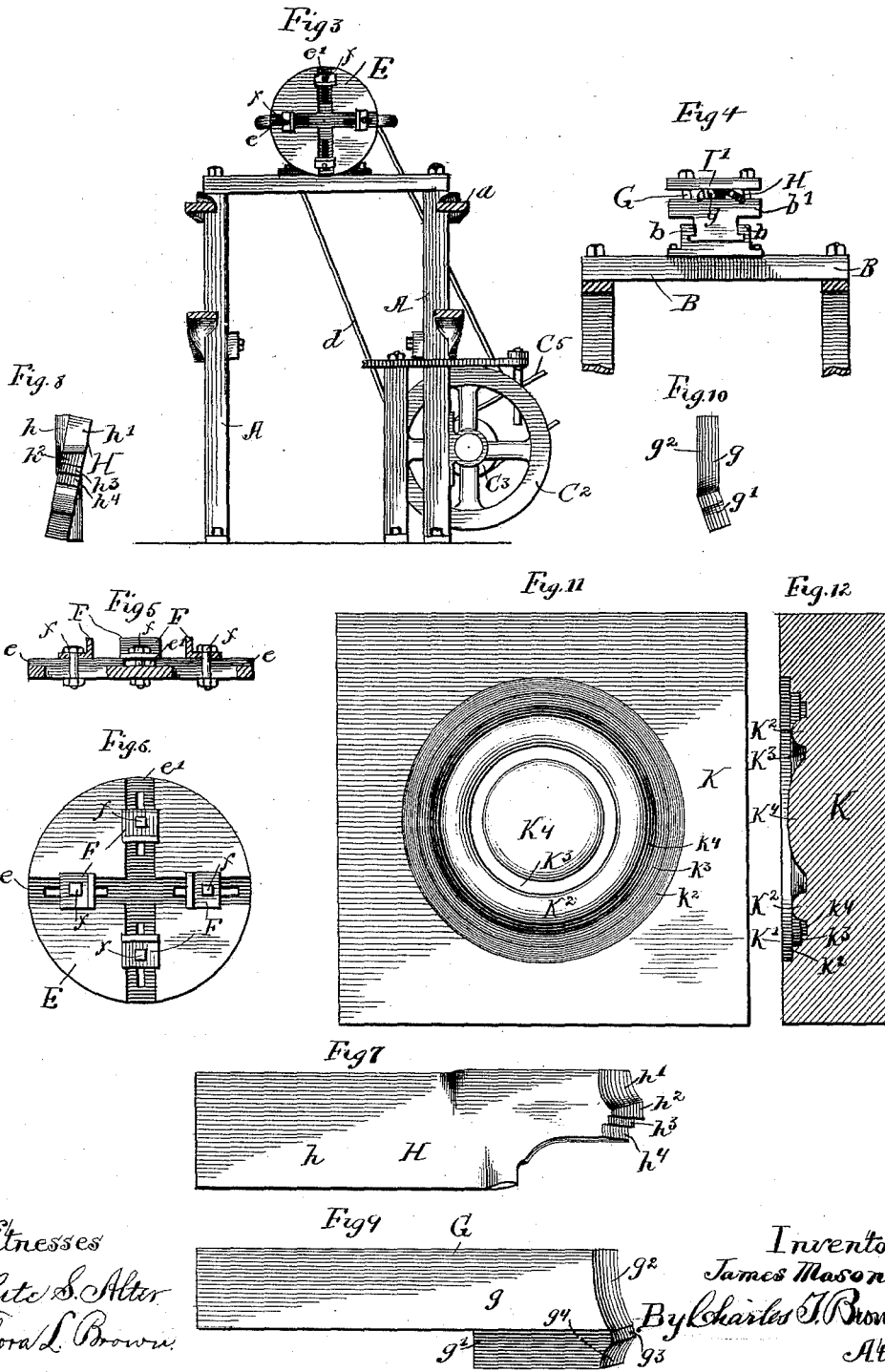

Witnesses
 Lute S. Alter
 Thora L. Brown.

Inventor
 James Mason,
 By Charles J. Brown,
 Atty.

(No Model.)

3 Sheets—Sheet 3.

J. MASON.

MACHINE FOR CUTTING ROSETTES IN CORNER CASING BLOCKS FOR
DOOR FRAMES, BOOK CASES, OR OTHER ARTICLES.

No. 466,963.

Patented Jan. 12, 1892.

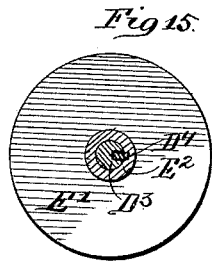
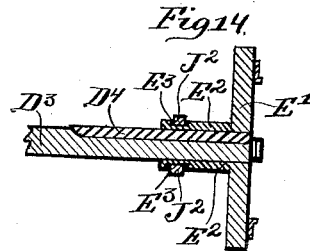
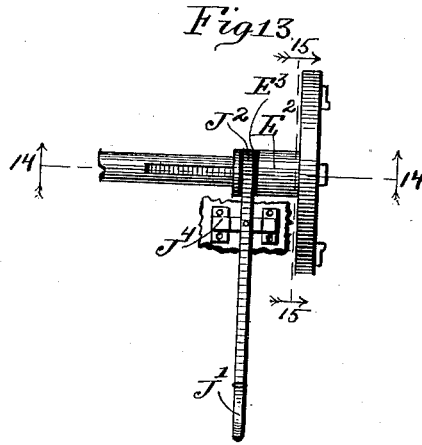
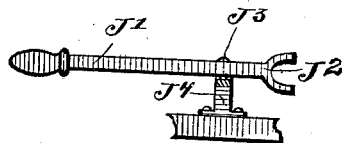

Fig 16.



Witnesses;
Lute S. Allen
Vessa G. Parrish.

Inventor;
James Mason,
 By *Charles J. Brown,*
Atty

UNITED STATES PATENT OFFICE.

JAMES MASON, OF CHICAGO, ILLINOIS.

MACHINE FOR CUTTING ROSETTES IN CORNER CASING-BLOCKS FOR DOOR-FRAMES, BOOK-CASES, OR OTHER ARTICLES.

SPECIFICATION forming part of Letters Patent No. 466,963, dated January 12, 1892.

Application filed February 19, 1891. Serial No. 382,047. (No model.)

To all whom it may concern:

Be it known that I, JAMES MASON, a citizen of the United States, residing at Chicago, in the county of Cook and State of Illinois, have
5 invented certain new and useful Improvements in a Machine for Cutting Rosettes in Corner Casing-Blocks for Door-Frames, Book-Cases, and other Articles, of which the following is a specification.

10 Heretofore in machines for cutting rosettes on corner casing-blocks the cutting-tools of the machine have been rapidly rotated in such manner that the ends thereof come in contact with the corner casing-block, which
15 has been firmly held in a sliding frame when slid forward together with such frame toward the rotating tools, and the ornamentation desired in the corner casing-block thereby cut. After the cutting of the ornamentation thereon the corner casing-block has been removed
20 from the sliding frame and secured on a rotatable head or disk of a second machine and by the turning of such head or disk made to rapidly revolve and by the holding of a piece
25 of sand-paper thereto properly sandpapered. The corner casing-block is thus completed and then removed from the rotating head or disk.

30 The purpose of this invention is to obtain a machine for cutting such corner casing-blocks, wherein the corner casing-block shall be rotated while the ornamentation thereof is being cut thereon by the tools, such tools not rotating and being firmly secured in a
35 sliding frame and adapted to be slid into contact with the revolving corner casing-block. The ends of such tools are thus brought properly into contact with the face of the corner casing-block, and the ornamentation cut thereon, after which the cutting-
40 tools are slid back from contact with the face of the corner casing-block and sandpaper applied thereto while such corner casing-block is still revolving and the block
45 completely finished before being taken from the machine.

By this machine I am enabled to make corner casing-blocks having the same designs in the ornamentation thereof as those heretofore made and in much less time.

I have illustrated my invention by the

drawings accompanying and forming a part of this specification, in which—

Figure 1 is an elevation of a machine embodying the invention; Fig. 2, a plan thereof; 55 Fig. 3, an end elevation thereof with the cutter-carrying frame removed; Fig. 4, an end elevation of the sliding frame in which the cutting-tools are held, viewed on line 4 4 of Fig. 2 in the direction of the arrows; Fig. 5, 60 a central sectional view of a rotatable head or disk on which the corner casing-block is held and with which it rotates while the ornamentation thereon is being cut; Fig. 6, a front elevation of such rotatable head or disk; 65 Fig. 7, a front elevation of one of the cutting-tools; Fig. 8, an end elevation of the tool illustrated in Fig. 7; Fig. 9, a front elevation of the other of the cutting-tools of the machine; Fig. 10, an end elevation of the tool illustrated in 70 Fig. 9; Fig. 11, a front elevation of a corner casing-block cut by the tools illustrated in Figs. 7, 8, 9, and 10, used with or on the machine illustrated in Figs. 1 to 6, both inclusive; and Fig. 12, a sectional view of such corner casing-block. 75 Fig. 13 is a top plan view of a modification of the invention, which permits the rotating corner casing-block to approach rigidly-held stationary tools. Fig. 14 is a sectional view thereof on line 14 14 of Fig. 13, viewed in the 80 direction of the arrows. Fig. 15 is a sectional view on line 15 15 of Fig. 13, viewed in the direction of the arrows; and Fig. 16 is a side elevation of a lever forming part of the modification by which the lateral movement of the 85 rotating head-block is secured while the head-block is rotating.

Similar letters of reference indicate the same parts where more than one view thereof is shown in the drawings. 90

A B is the frame of the machine, part A being that part of the frame in which the rotatable parts of the machine are placed, and part B that part whereon the sliding parts of the machine are placed. 95

b b are grooves or tracks wherein or whereon the sliding head b' moves. The cutting-tools of the machine are firmly held in the sliding head b'.

C is a rotatable shaft on which are rigidly 100 secured pulleys C' C² C³.

C⁴ is a loose pulley or idler on shaft C.

C⁵ is a belt by which the machine is driven.

C⁶ is a belt-shifting device having handle C⁷ thereon, by which the belt C⁵ is shifted from the idler C⁴ to driving-pulley C³ and back, as desired, such belt actuating the machine when on the pulley C³, but not driving the machine when on idler C⁴.

D is a rotatable shaft having pulleys D' D² rigidly secured thereto and having head or disk E at one end thereof, also rigidly secured thereto.

d is a driving-belt extending over pulleys C' D' or C² and D², as preferred. This belt *d* is illustrated in the drawings as extending over the pulleys C' and D'.

e e' are grooves in head E, and F F are blocks sliding in these grooves.

f f are bolts extending through the head E and through the sliding blocks F F, by means of which the sliding blocks are firmly secured in any desired position in the grooves *e e'*.

In the modification illustrated in Figs. 13 and 16, both inclusive, E' is the revolving wheel to which the corner casing-block to be ornamented by the rosette is firmly secured, and with which it rotates in the cutting, and E² is the hub thereof extending on shaft D³. Hub E² is made to revolve with shaft D³ by the key or spline D⁴, which extends into the shaft longitudinally therewith and into the hub E² of the wheel E', while at the same time the wheel E' and hub E² may slide or be slid on the shaft D³ and on the key or spline D⁴. The manner in which the position of the wheel E' is determined and controlled (longitudinally on shaft D³) is by putting the groove E³ around the hub E² and placing the fork of the pivoted lever J' (such fork being lettered J³) in the groove E³. Lever J' is pivoted on point J³ on standard J⁴, such standard being rigidly secured to the frame of the machine.

G H are cutting-tools held firmly in sliding head or block *b'* by plate I', which is clamped to the sliding head *b'* by bolts I.

J is a handle by which the sliding block *b'* is moved forward and backward on part B of the frame. K is the corner casing-block, and K' K² K³ K⁴ are the several beads and grooves forming the ornamentation of such corner casing-block.

k² k³ k⁴ are the different members forming the ornamentation K'.

The difficulty heretofore experienced in cutting a corner casing-block on a machine wherein such corner casing-block rotates and the cutting-tools do not rotate has been that the circular beads or moldings on such corner casing-block, particularly the one standing out from the main body of the design, has been split, cut, broken, or torn out from the corner casing-block, especially in the parts thereof crossing the grain of the wood of the block, and in order to obviate this difficulty I have, in addition to the devices hereinbefore described, found it necessary to use more than one cutting-tool. I have heretofore used two

cutting-tools, one of such cutting-tools cutting the ornamentation on the corner casing-block from the center thereof to about half-way out of such ornamentation and the other tool cutting the ornamentation the remainder of the way out. In using two cutting-tools for thus cutting the ornamentation of the corner casing-block one thereof must be secured in the sliding head *b'* so as to cut on the bottom edge thereof as the corner casing-block revolves, carrying the part of such block to be cut thereby up toward the tool, and the other thereof secured in such sliding head *b'* so as to cut on the upper edge thereof as the corner casing-block revolves, bringing the portion thereof to be cut down toward such tool, and such tools being so placed in the sliding head *b'* that one thereof is on one side of the center of the ornamentation and the other on the other side thereof. When arranged in this way, one of the tools will cut the ornamentation from the center thereof about half-way out and the other the remainder of the distance.

In corner casing-blocks having the kind of ornamentation thereon which this machine is adapted to cut there is a circular bead or molding extending out from the body of the ornamentation at about half-way of the distance from the center to the edge thereof, and these tools being arranged, as described, on each side of the center of the corner casing-block and so adapted to cut the ornamentation of the block. One of such tools cuts one-half of this circular bead or molding and the other thereof cuts the remainder of such bead or molding, and the liability to tear out pieces or portions of the circular bead or molding and thereby cause ragged and unsightly blotches therein, particularly at the point on the corner casing-block where the cutting-tools cross the grain of the wood of the block, is thereby almost entirely done away with. In addition to thus cutting the ornamentation on the corner casing-block by two tools, as described, one of such tools (the one lettered G and cutting the ornamentation from the center out toward the periphery thereof) is composed of two parts or portions, the one integral with the other, but placed in a plane intersecting the plane of the other at a very obtuse angle on the inside of the tool, or that side on which the cutting-edge is placed, so that the cutting-edges of each part or portion of such tool come in contact with and against the face of the corner casing-block in a suitable manner to best cut the ornamentation thereon without tearing the wood from the block, and the other of such tools (lettered H) has the cutting-edge thereof turned at an angle to the shank of the tool. The two parts or portions of the tool G are lettered, respectively, *g g'*. The cutting-edge of the part or portion *g* is lettered *g²*, and the cutting-edge of the other part or portion is lettered *g³ g⁴*. Cutting-edge *g²* cuts the center ornamentation K⁴ in the corner casing-block K, as illustrated

in Figs. 11 and 12. Cutting-edge g^2 cuts the circular groove K^3 and cutting-edge g^3 cuts about one-half of the circular bead or molding K^2 . h is the shank of tool H. This cutting-tool H has cutting-edges $h^1 h^2 h^3 h^4$. Cutting-edge h^1 cuts the outer half of the circular bead or molding K^2 and cutting-edges $h^2 h^3 h^4$ cut, respectively, members $k^2 k^3 k^4$ of the beading or ornamentation K^1 .

It is not to be understood that this machine is adapted to cut only the particular ornamentation upon the corner casing-block illustrated by Figs. 11 and 12 of the drawings and herein described, as by changing the shape of the cutting-edges of the tools, or one of them, any desired shape of turned mold can be made, the ornamentation produced thereby having a different appearance from that illustrated in Figs. 11 and 12 of the drawings; but the use of two cutting-tools and the placing of the cutting-edge of such tools in the proper angle to the horizontal plane extending through the center of the ornamentation on the face of the block as such block is being revolved and cut in the machine should in all cases be preserved, and also the projecting circular bead or molding corresponding with the bead or molding K^2 of Figs. 11 and 12 must be cut about one-half with one of the tools and the other half thereof with the other of the tools, placed as described in the sliding corner casing-block of the machine, so that one of such tools shall have its cutting-edge on the lower side thereof and the other on the upper side thereof, one being on one side of the center of the ornamentation of the corner casing-block and the other on the other side thereof.

In order to operate this machine, corner casing-block K is placed on disk E and clamps or sliding blocks $f f f f$ secured in place against the corner casing-block K to hold it in position. Belt C^5 is shifted from the loose pulley C^4 onto pulley C^3 and the block thereby rapidly rotated. Sliding head b^1 is then brought forward by handle J and the cutting-edges of the tools G H brought against the block K and the ornamentation thereon cut by such tools, after which the sliding head b^1 is slid back and the face of the block properly sandpapered while rotating and then removed from the machine in a finished condition.

It will be evident to those skilled in the art of turning wood that the face-plate E can be put on a wood-turning lathe and the cutters secured in a head adapted to be slid on the frame of the lathe, and that the result at-

tained will be the same as that attained in the machine herein described. It is evident, too, that if the face-plate or head E is feathered on shaft D so as to rotate therewith, but adapted to be longitudinally movable on such shaft D, the cutting-tools and sliding head b^1 , in which they are held, may be rigidly held in one position and the face-plate or head E, with the block K secured thereon, slid up to the cutting-tools; but such a change in the construction of this machine would involve no invention, as when the block on which the rosette is to be cut and the tools cutting the rosette thereon are considered solely with reference to each other it makes no difference whether a rapidly-revolving block is made to approach rigidly-held and stationary cutting-tools or whether the tools held rigidly and stationary, except so far as approaching the rapidly-revolving block, are made to approach such rapidly-rotating block, and a construction wherein the rotating block can be made to approach rigidly and stationary held cutting-tools is illustrated in Figs. 12 to 15, both inclusive, in the drawings, and the machine as so constructed would embody the herein-described invention.

Having thus described my invention, what I claim and desire to secure by Letters Patent of the United States, is—

In a machine for cutting corner casing-blocks, the combination of a rotatable face-plate adapted to have secured thereon a corner casing-block with cutting-tools and a sliding head, one of such cutting-tools secured in such sliding head with the cutting-edge thereof on its under side and the other one with its cutting-edge on the upper side thereof, and one of such tools extending from the center of the ornamentation produced on the corner casing-block out toward the circumference of such ornamentation on one side of such center and the other placed on the other side of the center of such ornamentation and extending from about half-way out thereof to the circumference thereof, whereby when the face-plate and block are rotated and the cutting-tools are slid against the block one of such tools will cut about one-half of the ornamentation on the block and the other of such tools will simultaneously cut the other half thereof, substantially as described.

JAMES MASON.

Witnesses:

ADOLPH H. G. ELTEN,
CHARLES T. BROWN.